



TURBO LIQUIDISER TRX-21

1-speed turbo-mixer



DYNAMIC PREPARATION
TURBO LIQUIDISERS



FEATURES AND BENEFITS

- ✓ Fully manufactured in stainless steel 18/10.
- ✓ For mixing and liquidising directly in the pot or pan for making consommés, soups, omelettes, mayonnaise, etc.
- ✓ Designed for large yields and for frequent use and cleaning, ideal for kitchens with a large production and the food industry.
- ✓ 1-speed model.
- ✓ Ease of use: can be moved in several directions, adjustable height, fitted on a trolley with 4 non-slip rubber wheels, 2 of them with brakes.
- ✓ Arm: 600 mm long for blending in any type of cooking pot, whether round or rectangular, equally effective throughout the whole pot.
- ✓ Balanced liquidiser arm: stops the arm falling or tipping back when not locked.
- ✓ Arm securing lever: allows you to lock the blender with one hand while holding the trolley with the other.
- ✓ Watertight, tilted control panel: easy access even during use.
- ✓ Control panel located on the trolley, making the arm more agile, with better mobility.
- ✓ Control panel with built-in timer: you can leave the machine running for up to 60 minutes without the need for user involvement.
- ✓ Wiring incorporated into the trolley tubes: The work area is free of cables, so as not to hinder the movement of the blender arm.
- ✓ Supports for storing the power supply cable: prevents the cable getting tangled and inconveniencing other users.
- ✓ The turbine, disc and grille are very easy to remove for cleaning: no tools needed.
- ✓ The turbine, guard, disc and attachment can be cleaned in dishwashers.
- ✓ For use with 3 easily interchangeable attachments, which meet the needs of all users and ingredients.
- ✓ 21D for fibrous ingredients
- ✓ Standard 30D multi-use attachment
- ✓ 42D attachment for very fine blending
- ✓
- ✓ Safety microswitch to control the work position: prevents the turbine working if the arm is too high or low.
- ✓ Safety guard on the liquidiser head and safety device that cuts out the power supply.

SALES DESCRIPTION

Turbo-blender designed to work in up to 800 litre / 130 gal. bowls.



SAMMIC, S.L.
Basiglio, 1 - 20720 ASK011TA
www.sammic.com



www.sammic.co.uk

Food Service Equipment Manufacturer

Unit 2, Trevanth Road
Troon Industrial Park
LE4 9LS - Leicester

uksales@sammic.com
Tel.: +44 0116 246 1900



Project	Date
Item	Qty
Approved	

product sheet
updated 06/03/2018



TURBO LIQUIDISER TRX-21

1-speed turbo-mixer



SPECIFICATIONS

Maximum recipient capacity: 800 l

Liquidising arm length: 600 mm

Total loading: 2200 W

Speed (in liquid): 1500 rpm

External dimensions (WxDxH)

✓ Width: 568 mm

✓ Depth: 1643 mm (963 mm)

✓ Height: 1219 mm (1651 mm)

Net weight: 96 Kg

Noise level (1m.): <70 dB(A)

Background noise: 32 dB(A)

Crated dimensions

1030 x 710 x 1840 mm

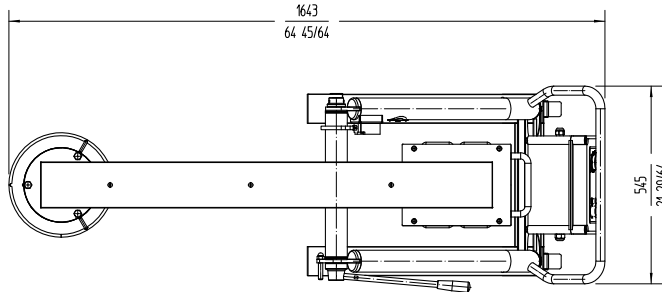
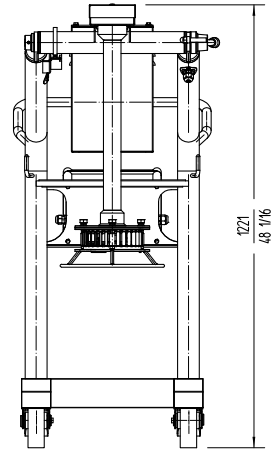
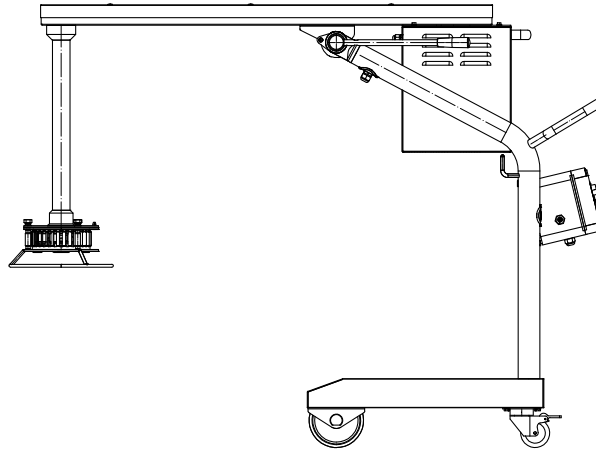

AVAILABLE MODELS

3030501 Turbo liquidiser TRX-21 230-400/50/3N

* Ask for special versions availability

ACCESSORIES

Grids for TRX

DYNAMIC PREPARATION
TURBO LIQUIDISERS



www.sammic.co.uk

Food Service Equipment Manufacturer

Unit 2, Trevanah Road
Troon Industrial Park
LE4 9LS - Leicester

uksales@sammic.com
Tel.: +44 0116 246 1900



Project

Date

Item

Qty

Approved

product sheet
updated 06/03/2018